

TYPICAL CROSS SECTION AT ENDWALL

# Floors Supported	width w	thickness t
1	12	6
2	16	6
3	19	8

NOTE: FOOTING SIZES SHOWN ARE GENERALLY ACCEPTED. HOWEVER, SOME AREAS REQUIRED SPECIAL CONSIDERATION. FOOTING PROJECTIONS SHALL BE 2 INCHES MIN. AND SHALL NOT EXCEED THE THICKNESS OF THE FOOTING.

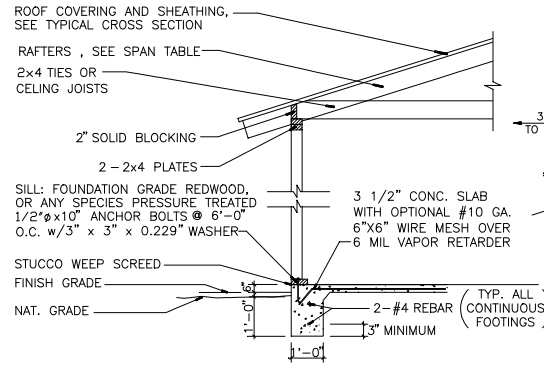

CONCRETE FLOOR

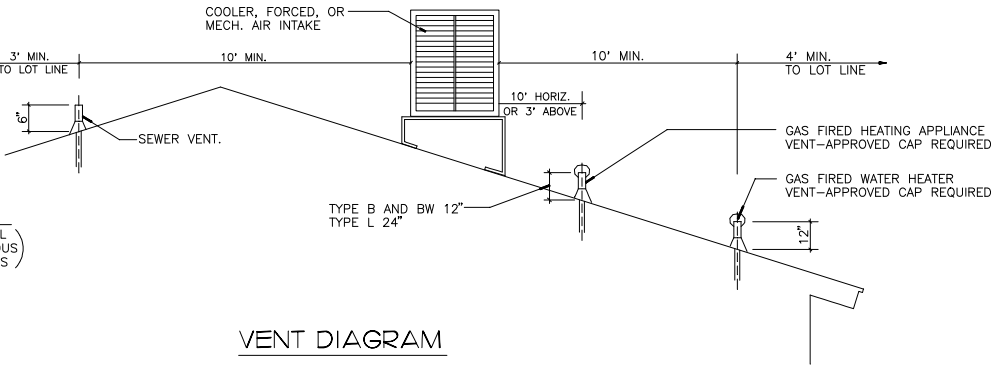

VENT DIAGRAM

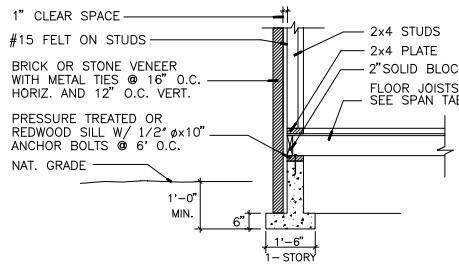

VENEERED WALL

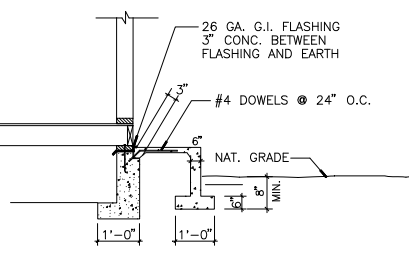

CONCRETE PORCH

K:\BuildingDev\Office Survey\Drafting\ARCHIVE\COREL\BID\SPAN\_TB3a.DWG

Kern County Public Works  
 Building & Development  
 Building Inspection Division  
 2700 M Street, Suite 100  
 Bakersfield, CA. 93301 (661) 862-8650

Date: Dec. 13, 1995  
 Rev: 1/08 - 2007 CBC  
 Rev: 3/11 - 2010 CBC  
 Rev: 1/14 - 2013 CRC  
 Rev: 12/16 - 2016 CRC

TYPICAL DWELLING  
 FRAMING DETAILS